

T-25G-SM-10KM 25Gb/s SFP28 1310nm 10km Transceiver

FEATURES

- Supports 24.3Gb/s to 26.5Gb/s bit rates
- _ Up to 10km transmission on SMF
- _ DFB Laser and PIN receiver
- _ Metal enclosure, for lower EMI
- _ 2-wire interface with integrated Digital Diagnostic monitoring
- _ Specifications compliant with SFF 8472
- _ Compliant with SFP+ MSA with LC connector
- _ Single 3.3V power supply
- _ Power dissipation < 1.2 W
- _ Case operating temperature range:
Commercial: 0°C to +70°C
Industrial: -40°C to +85°C

APPLICATIONS

- _ 25G Ethernet
- _ CPRI 10

STANDARD

- _ Compliant to SFF-8431
- _ Compliant to SFF 8472
- _ Compliant to IEEE 802.3 CC
- _ RoHS Compliant.



Ordering Information

Part Number	Product Description
T-25G-SM-10KM	25Gb/s SFP28 SM, 10 km on a standard single mode fiber DDM

Absolute Maximum Ratings

Parameter	Symbol	Min.	Typ.	Max.	Unit	Note
Storage Temperature	T _s	-40	-	85	°C	
Relative Humidity	RH	5	-	95	%	
Power Supply Voltage	VCC	-0.3	-	4	V	

Recommended Operating Conditions

Parameter	Symbol	Min.	Typ.	Max.	Unit	Note
Case Operating Temperature	Tcase	0		70	°C	Commercial
		-40		85	°C	Industrial
Power Supply Voltage	VCC	3.14	3.3	3.47	V	
Power Supply Current	ICC			300	mA	Commercial
				360	mA	Industrial
Data Rate	BR	24.3	25.78	26.5	Gbps	
Transmission Distance	TD		-	10	km	
Coupled fiber		S	ingle mode fiber			9/125um SMF

Optical Characteristics

Parameter	Symbol	Min	Typ	Max	Unit	NOTE
Transmitter						
Output Opt. Power	P _{OUT}	-5		2	dBm	1
Optical Wavelength	λ	1295		1325	nm	
Spectral Width (-20dB)	σ			1	nm	
Optical Extinction Ratio	ER	3.5			dB	
Receiver						
Rx Sensitivity	R _{SENS}			-13.3	dBm	2
Input Saturation Power (Overload)	P _{SAT}	0.5			dBm	
Wavelength Range	λ_c	1295		1325	nm	
LOS De -Assert	LOSD			-14	dBm	
LOS Assert	LOSA	-30			dBm	
LOS Hysteresis		0.5			dB	

Notes:

- Class 1 Laser Safety per FDA/CDRH and IEC-825-1 regulations.
- Measured with a PRBS 2³¹-1 test pattern, @25.78Gb/s, BER @5*10⁻⁵.

Electrical Characteristics

Parameter	Symbol	Min	Typ	Max	Unit	NOTE
Supply Voltage	Vcc	3.14	3.3	3.46	V	
Supply Current	Icc			300	mA	Commercial

				360	mA	Industrial
Transmitter						
Input differential impedance	Rin		100		Ω	1
Single ended data input swing	Vin,pp	180		800	mV	
Transmit Disable Voltage	VD	Vcc-1.3		Vcc	V	
Transmit Enable Voltage	VEN	Vee		Vee+ 0.8	V	2
Receiver						
Differential data output swing	Vout,pp	300		850	mV	3
LOS Fault	VLOS fault	Vcc-1.3		VccHOST	V	4
LOS Normal	VLOS norm	Vee		Vee+0.8	V	4

Notes:

1. Connected directly to TX data input pins. AC coupled thereafter.
2. Or open circuit.
3. Into 100 ohms differential termination.
4. Loss Of Signal is LVTTTL. Logic 0 indicates normal operation; logic 1 indicates no signal detected.

Pin Assignment

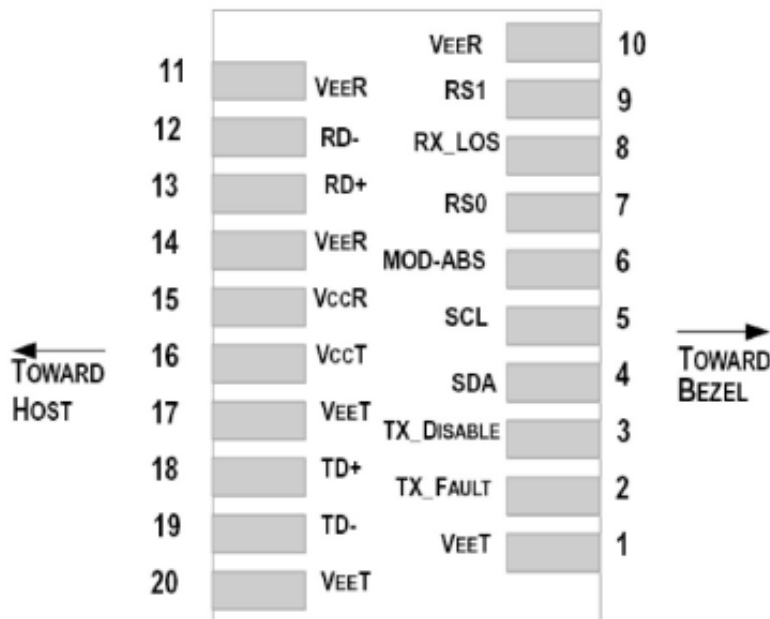

Pin out of Connector Block on Host Board

Pin	Symbol	Name/Description	NOTE
1	VeeT	Transmitter Ground	1
2	TX Fault	Transmitter Fault Indication	3
3	TX Disable	Transmitter Disable	3
4	SDA	Module Definition 2	3
5	SCL	Module Definition 1	3
6	MOD_ABS	Module Definition 0	3
7	RS0	RX Rate Select (LVTTTL).	3
8	LOS	Loss of Signal	3
9	RS1	TX Rate Select (LVTTTL).	1
10	VeeR	Receiver ground	1
11	VeeR	Receiver ground	1
12	RD-	Inv. Received Data Out	3
13	RD+	Received Data Out	3
14	VeeR	Receiver ground	1
15	VccR	Receiver Power Supply	2
16	VccT	Transmitter Power Supply	2
17	VeeT	Transmitter Ground	1
18	TD+	Transmit Data In	3
19	TD-	Inv. Transmit Data In	3
20	VeeT	Transmitter Ground	1

Notes:

1) TX Fault is an open collector/drain output, which should be pulled up with a 4.7K – 10KΩ resistor on the host board.

Pull up voltage

between 2.0V and $V_{ccT/R}+0.3V$. When high, output indicates a laser fault of some kind. Low indicates normal operation. In the low state,

the output will be pulled to $< 0.8V$.

2) TX disable is an input that is used to shut down the transmitter optical output. It is pulled up within the module with a 4.7K – 10 KΩ

resistor. Its states are: Low (0 – 0.8V): Transmitter on (>0.8 , $< 2.0V$): Undefined High (2.0 – 3.465V): Transmitter Disabled Open:

Transmitter Disabled

3) Module Absent, connected to VeeT or VeeR in the module.

4) LOS (Loss of Signal) is an open collector/drain output, which should be pulled up with a 4.7K – 10KΩ resistor. Pull up voltage between

2.0V and $V_{ccT/R}+0.3V$. When high, this output indicates the received optical power is below the worst-case receiver sensitivity (as defined

by the standard in use). Low indicates normal operation. In the low state, the output will be pulled to $< 0.8V$.

- 5) The module signal ground contacts, VeeR and VeeT, should be isolated from the module case.
- 6) RD-/+ : These are the differential receiver outputs. They are AC coupled 100Ω differential lines which should be terminated with 100Ω (differential) at the user SERDES. The AC coupling is done inside the module and is thus not required on the host board. The voltage swing on these lines will be between 350 and 700 Mv differential (175 –350 Mv single ended) when properly terminated.
- 7) VccR and VccT are the receiver and transmitter power supplies. They are defined as 3.3V ±5% at the SFP+ connector pin. Maximum supply current is 680Ma. Recommended host board power supply filtering is shown below. Inductors with DC resistance of less than 1 ohm should be used in order to maintain the required voltage at the SFP+ input pin with 3.3V supply voltage. When the recommended supplyfiltering network is used, hot plugging of the SFP+ transceiver module will result in an inrush current of no more than 30Ma greater than the steady state value. VccR and VccT may be internally connected within the SFP+ transceiver module.
- 8) TD-/+ : These are the differential transmitter inputs. They are AC-coupled, differential lines with 100Ω differential termination inside the module. The AC coupling is done inside the module and is thus not required on the host board. The inputs will accept differential swings of 150 – 1200 Mv (75 – 600Mv single-ended).

Digital Diagnostic Functions

SFP28-25G-LR transceivers support the 2-wire serial communication protocol as defined in the SFP+ MSA.

The standard SFP serial ID provides access to identification information that describes the transceiver's capabilities, standard interfaces, manufacturer, and other information.

Additionally, SFP+ transceivers provide a unique enhanced digital diagnostic monitoring interface, which allows real-time access to device operating parameters such as transceiver temperature, laser bias current, transmitted optical power, received optical power and transceiver supply voltage. It also defines a sophisticated system of alarm and warning flags, which alerts end-users when particular operating parameters are outside of a factory set normal range.

The SFP MSA defines a 256-byte memory map in EEPROM that is accessible over a 2-wire serial interface at the 8 bit address 1010000X (A0h). The digital diagnostic monitoring interface makes use of the 8 bit address 1010001X (A2h), so the originally defined serial ID memory map remains unchanged.

The operating and diagnostics information is monitored and reported by a Digital Diagnostics Transceiver Controller (DDTC) inside the transceiver, which is accessed through a 2-wire serial interface. When the serial protocol is activated, the serial clock signal (SCL, Mod Def 1) is generated by the host. The positive edge clocks data into the SFP transceiver into those segments of the E2PROM that are not write-protected. The negative edge clocks data from the SFP transceiver.

The serial data signal (SDA, Mod Def 2) is bi-directional for serial data transfer. The host uses SDA in conjunction with SCL to mark the start and end of serial protocol activation. The memories are organized as a series of 8-bit data words that can be addressed individually or sequentially.

Host - Transceiver Interface Block Diagram

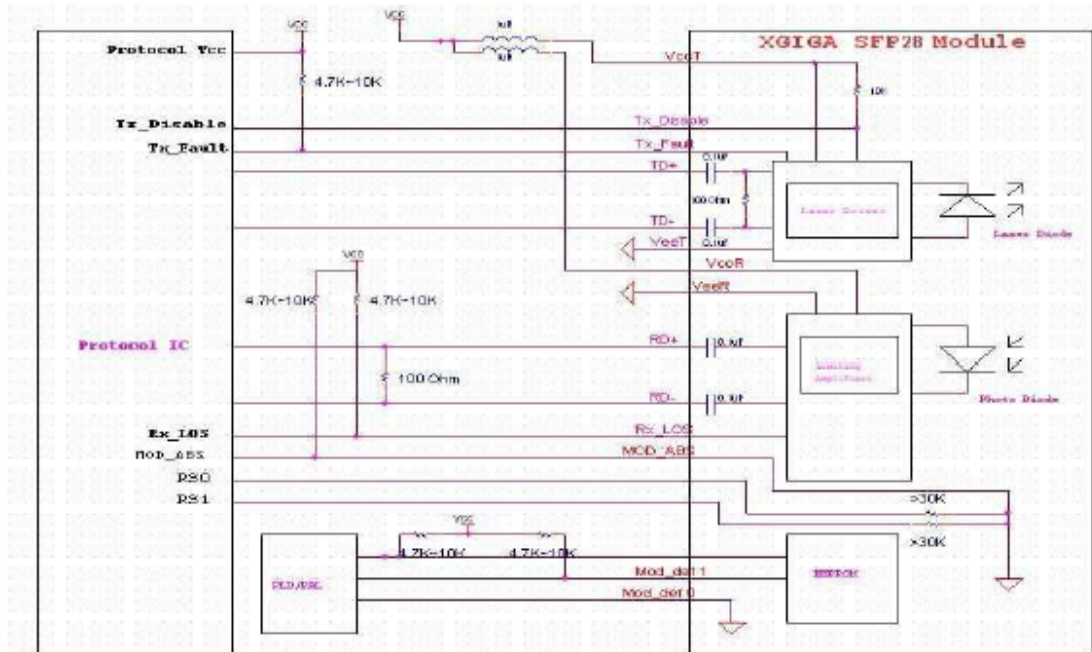

Outline Dimensions

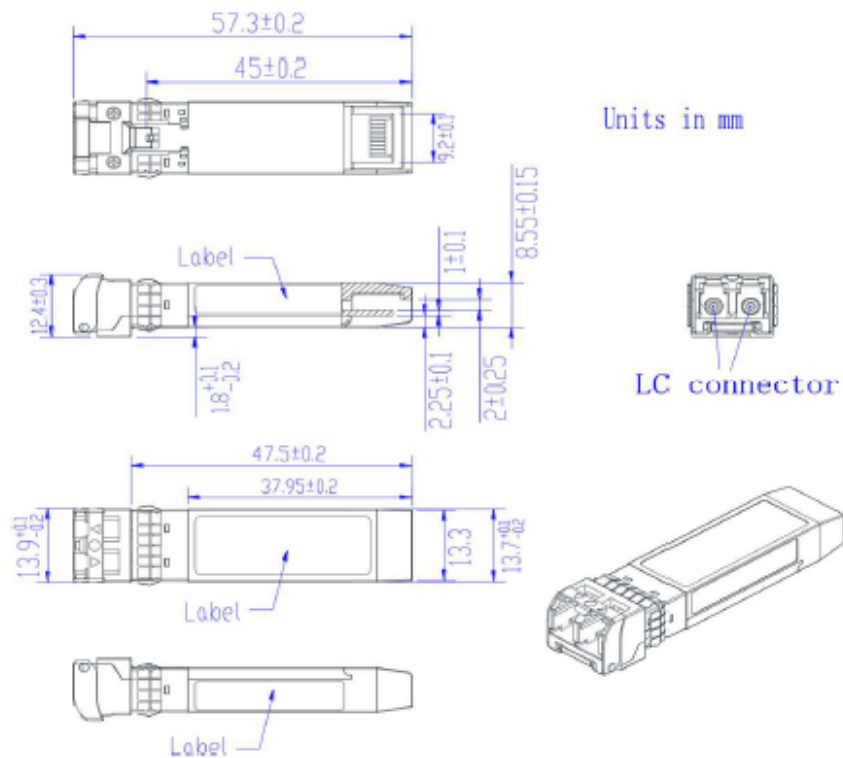

**Notice:**

T-TECH reserves the right to make changes to or discontinue any optical link product or service identified in this publication, without notice, in order to improve design and/or performance. Applications that are described herein for any of the optical link products are for illustrative purposes only. T-TECH makes no representation or warranty that such applications will be suitable for the specified use without further testing or modification.

Contact:

E-mail:sales@t-techvip.com

<http://www.t-techvip.com>